

# Tissue Factory: Conceptual Design of a Modular System for the *in Vitro* Generation of Functional Tissues

W.W. MINUTH, Ph.D., R. STREHL, Ph.D., and K. SCHUMACHER, M.D.

## ABSTRACT

Tissue factory is a modular system designed to generate artificial tissues under optimal perfusion culture conditions. The microenvironment within the culture containers can be fine-tuned to meet the physiological needs of individual tissues, so that the generation of differentiated three-dimensional tissue constructs becomes possible. An optimal physiological environment is created by modulating a liquid phase as well as an artificial interstitium surrounding the growing construct. An innovative construction principle allows production of tissue culture containers, gas exchangers, and gas expanders at minimal material expenditure. Therefore it will be possible for the first time to produce sterile one-way perfusion culture modules for the generation of artificial tissues. The modules can be used separately as well as in a combined module. The system is designed to provide a possible platform for the standardized production of artificial tissues for future applications in biomedicine.

## INTRODUCTION

MANY TISSUE-ENGINEERING APPLICATIONS aim at developing functional tissues from cells in combination with a suitable matrix to support and accelerate regenerative healing.<sup>1,2</sup> Stem cells<sup>3-6</sup> as well as cells from most adult tissues and organs<sup>7</sup> can generally be used for these purposes. In step 1, cells are isolated and expanded in culture to obtain a sufficient cell mass. In step 2, cells are seeded onto a three-dimensional scaffold to serve as a growth matrix, thus determining the structure of the construct. In that manner the four basic tissue groups with their specific characteristics can be produced *in vitro* to regenerate loss of epithelium,<sup>8,9</sup> connective tissue injury,<sup>10-13</sup> as well as degeneration of muscle<sup>14,15</sup> and neural tissue.<sup>16,17</sup>

Although the expansion of isolated cells in petri dishes poses no great difficulties, developing tissue constructs often show morphological, physiological, and biochemical changes caused by dedifferentiation.<sup>18-20</sup> Numerous studies have shown that the quality of artificial tissue

highly depends on scaffolds,<sup>21-24</sup> cell attachment,<sup>25,26</sup> intercellular communication<sup>27-29</sup> and the culture conditions.<sup>30-32</sup> All these factors must complement one another to prevent the development of atypical features. Characteristic examples are the expression of atypical collagen in tissue-engineered cartilage and bone constructs,<sup>33-35</sup> the calcification of artificial heart valves,<sup>36</sup> or loss of their endothelial coating,<sup>37,38</sup> as well as the downregulation of specific cellular functions that can be observed in liver,<sup>39,40</sup> pancreatic,<sup>41-43</sup> and kidney<sup>44,45</sup> constructs.

## TISSUE CULTURE

Years of experiments have shown that it is not possible to generate fully functional tissue within the static environment of a culture dish (Fig. 1a). This can be accounted for by the fact that tissue development *in vivo* is governed by a multitude of cellular and extracellular influences that cannot simply be replaced by an individual growth factor *in vitro*. Hence the need for a culture sys-

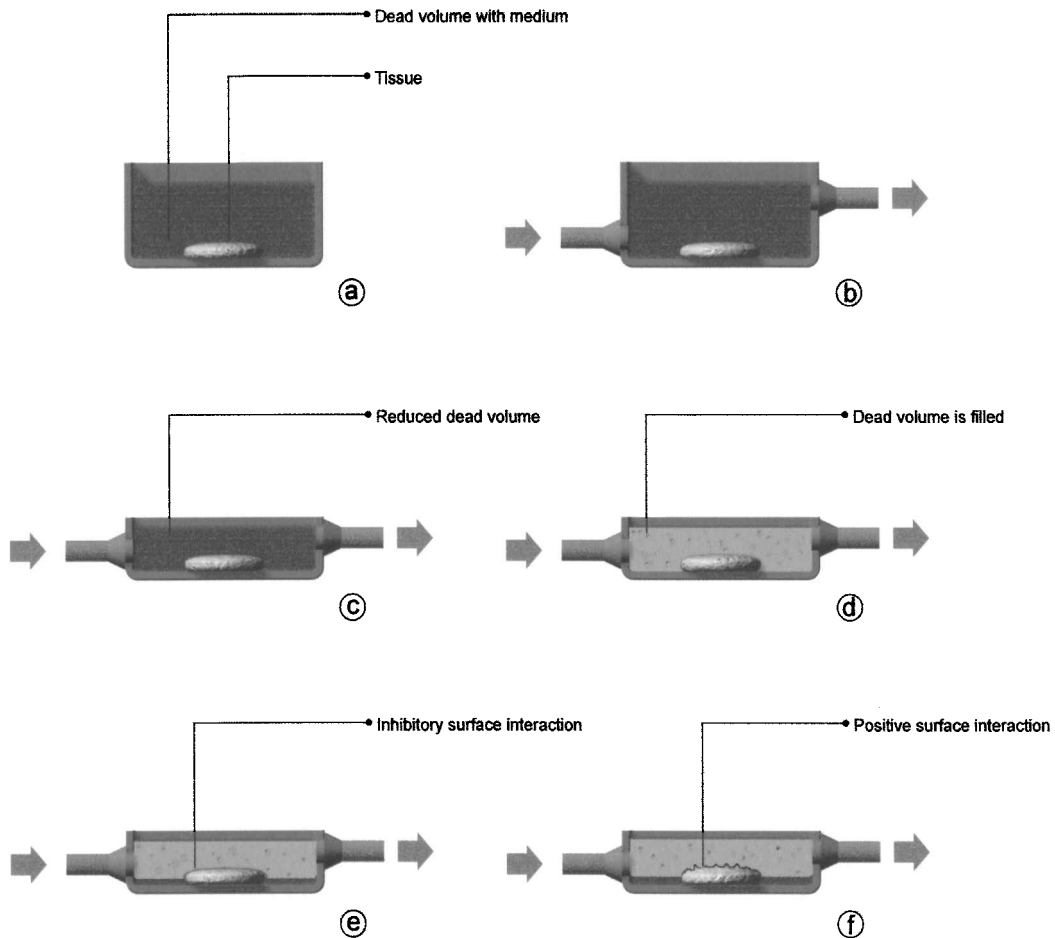

**FIG. 1.** Schematic representations of reduction of dead volume in tissue cultures. (a) Tissue in contact with the bottom of a culture dish. (b) Tissue in a conventional perfusion container. Tissue is in contact with the bottom of the container. Above there is a large volume of culture medium. (c) Reduction of the dead volume can be accomplished by decreasing the height of the container. (d) The remaining dead volume is filled with an artificial interstitium. This interstitial material can be designed to be growth inhibiting (e) or growth promoting (f).

tem is given that allows the simulation of specific environments for individual tissues to achieve a high degree of cellular differentiation. To overcome the technical limitations of a culture dish different kinds of perfusion culture container have been constructed.<sup>46–49</sup> However, to date all perfusion culture containers show a significant dead space around the tissue construct that is taken up by culture medium (Fig. 1b). This fluid-filled space can cause substantial hydraulic effects and passes pressure differences directly onto the cultured tissue. The dead volume is also a preferred site for gas bubbles to accumulate. The aggregation of gas bubbles is problematic, because the supply of culture medium is shortened regionally and even more so because the surface tension of the bubbles<sup>50</sup> can damage the developing tissue. The dead volume can be reduced by decreasing the height of the container (Fig. 1c).

### SIMULATION OF AN ARTIFICIAL INTERSTITIUM

To optimize conditions at the interface of developing tissue and perfusion culture container a lowered volume and more equally distributed fluid pressure must be obtained. Dissolved respiratory gases must be delivered to the tissue continuously without formation of gas bubbles. Properties of the immediate environment of the developing tissue must be adjustable from growth inhibiting to growth promoting. The technical solution is to fill the culture container with an artificial interstitium consisting of highly porous biocompatible material that decreases fluid pressure and distributes pressure more evenly across the construct by capillary effects (Fig. 1d). This material will provide mechanical protection to the tissue and minimize the dead space within the culture container. These

materials could be in direct contact with the construct and their surface could be engineered individually to modulate growth and differentiation. A negative surface interaction could be growth inhibitory (Fig. 1e) whereas a positive surface interaction could lead to directional growth of the construct (Fig. 1f). Consequently, the border between growing tissue construct and interstitium as well as the surface contour could be experimentally defined (see Fig. 4). The artificial interstitial network could be coated with defined extracellular matrix proteins locally to induce guided growth and development of three-dimensional tissue structures. A further option is to link morphogens, growth factors, or hormones to the artificial capillary network.<sup>51,52</sup> During matrix degradation these substances will be released in a fashion like matricellular proteins in immediate vicinity to the developing tissue and contribute to its functional maturation. By releasing bound growth factors and providing extracellular guide structures the artificial capillary network could promote outgrowth of cells from the tissue construct into the surrounding matrix, thus leading to an increase in size. It is also possible that such factors are not added to the culture medium any more, but are added exclusively to the artificial interstitium. It will increase the local bioavailability and will save costs.

### MATERIALS FOR AN ARTIFICIAL INTERSTITIUM

To construct an artificial interstitium natural or chemically refined extracellular matrix proteins could be used. Possible filling materials are fleeces from cellulose, fiberglass, wool, or silk as well as synthetic sponges from biopolymers such as polyester or polyurethane and nat-

ural cell-free extracellular matrices. For example, collagen preparations taken from skin, bone, cartilage, horn, or hoof of various species or tissue preparations such as air bladder, cockscomb, and trachea are prospective materials.<sup>53,54</sup> Other matrix proteins that affect tissue development such as proteoglycans, fibronectin, vitronectin, and laminins can remain in the preparation, can be removed, or can even be added specifically.

Another possible source of artificial interstitial matrices is recombinant matrix proteins. Analogous to the amino acid sequence of known structural proteins, artificial collagenous or noncollagenous monomers could be synthesized as recombinant extracellular matrix proteins.<sup>55,56</sup> These could be polymerized into three-dimensional networks of defined mesh. In contrast to natural collagens, the constructs could be optimized regarding their functional qualities. During the assembly of recombinant matrix proteins additional motifs can be added to the natural sequence. Such motifs are of particular importance for cell adhesion because of their affinity for cellular anchoring proteins such as integrins, cadherins, immunoglobulins, and selectins. A well-known cell-binding motif consists, for example, of Arg-Gly-Asp (RGD sequence) and is found in vitronectin, fibronectin, and collagens. Tyr-Ile-Gly-Ser-Arg (YIGSR sequence) occurs in  $\beta_1$ -laminin. Arg-Glu-Asp-Val (REDV sequence) is found in fibronectin.<sup>57-59</sup> Using these and similar motifs it is possible to incorporate defined signals for cell attachment, cell migration, mitosis, and differentiation into the matrix and thereby control cellular behavior at the border of the artificial interstitium (Figs. 2-4).

Artificial interstitium can also be produced from organic polymers that are dotted with functional groups. RGD motifs, for example, can be incorporated into poly-

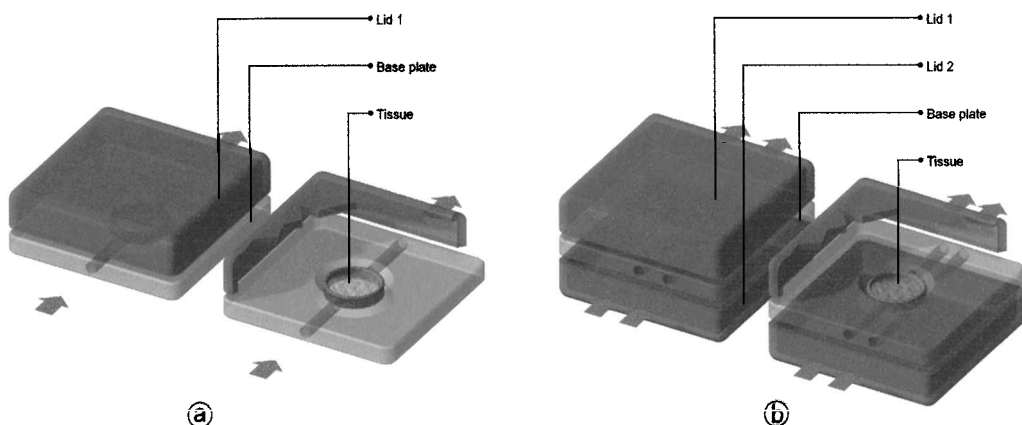

**FIG. 2.** Construction principle of culture containers with an artificial interstitium. (a) A perfusion container consists of a base plate to hold the developing tissue. The container is sealed with a lid filled with artificial interstitium. (b) A gradient perfusion container consists of a base plate with an opening for the developing tissue. Both sides of the plate are sealed with lids that contain artificial interstitium.

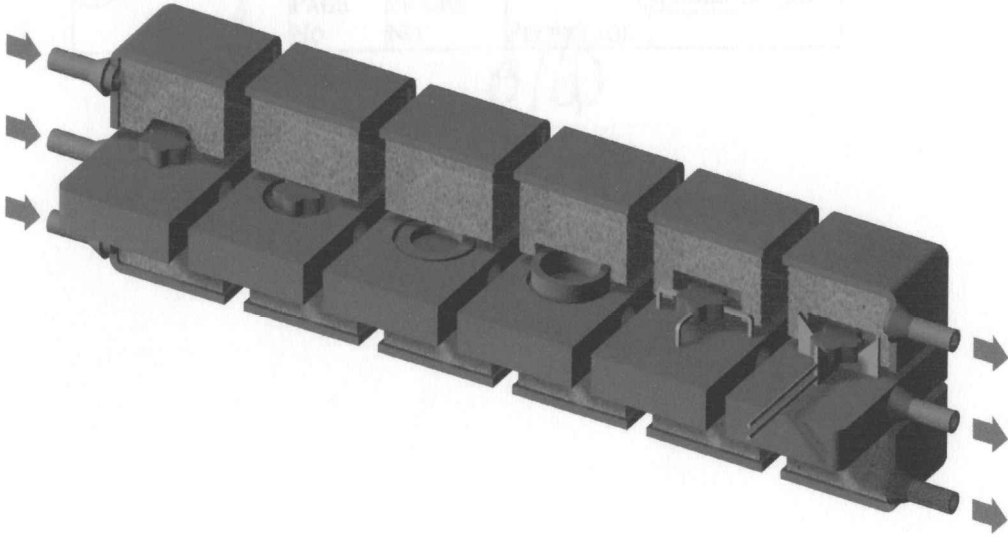

**FIG. 3.** Schematic representation of gradient perfusion containers with a basal plate and two lids each. The basal plate can house a variety of different tissue carriers with a diameter ranging between 13 and 47 mm.

ethylenetherephthalate (PET), polytetrafluoroethylene (PTFE), polyvinyl alcohol (PVA), and polyacrylamide and polyurethane polymers.<sup>60,61</sup> Surface modifications are possible on hydrophilic polymers such as polyvinylpyrrolidone (PVP), polyethyleneglycol (PEG) polyethyleneoxide (PEO), and polyhydroxyethylenemethacrylate (HEMA).

## TISSUE FACTORY

On the basis of our experimental knowledge we developed an improved perfusion culture system for the production of artificial tissues. The concept comprises

new culture containers with an artificial interstitium (Figs. 2–4) including transportation of culture medium with a minimum of gas bubbles (Fig. 5a), gas exchangers to adapt the optimal respiratory gas content (Fig. 5b), and gas expanders to eliminate gas bubbles (Fig. 5c). The culture system was named “Tissue Factory” for its modular design and flexibility in the production of tissue constructs under various culture conditions (Fig. 6).

## CULTURE CONTAINERS

Suitable culture containers are required in order to optimize culture conditions for differentiated tissue. One

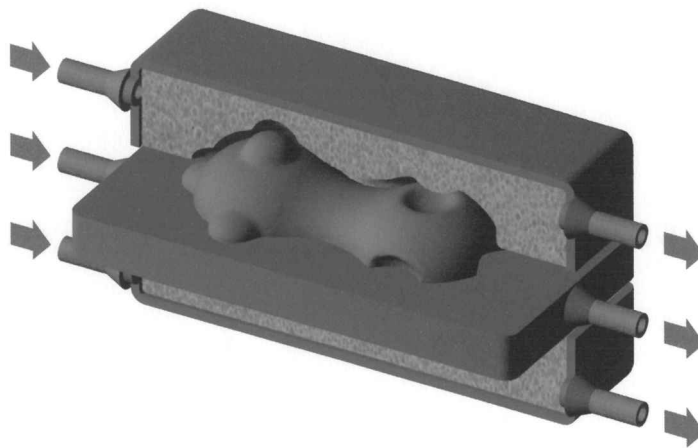

**FIG. 4.** Schematic representation of a connective tissue sample attached to the base plate of a perfusion container. The tissue is surrounded by artificial interstitium. The matrix contour of the interstitium can show indentations and elevations to determine the final shape of the tissue construct.

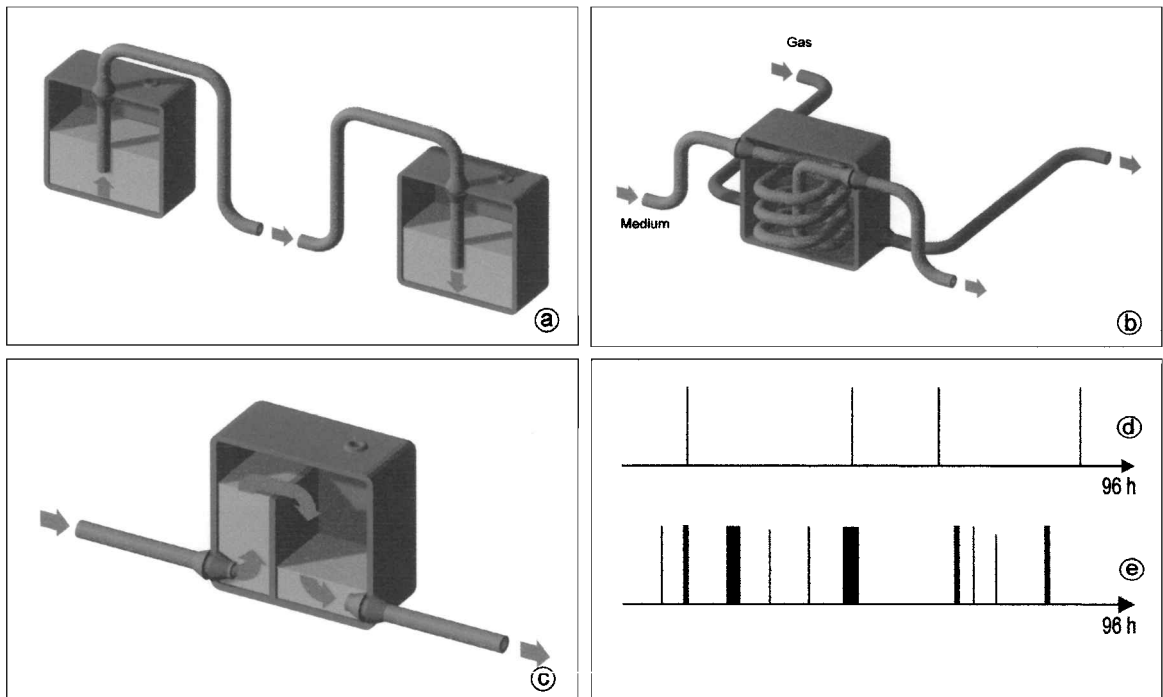

**FIG. 5.** Optimized technique for tissue culture. **(a)** To avoid the formation of gas bubbles at material transitions new bottle caps and one piece of continuous tubing is used. **(b)** Gas exchange without bubble formation in the module. There is a constant flow of the desired gas mix through the container, which houses a length of curled-up silicone tubing for culture medium. **(c)** Elimination of gas bubbles. Culture medium passes through a gas expander module with a fluid barrier. At this barrier gas bubbles are separated from the fluid and trapped in the container. **(d)** Registration of few gas bubbles in transported culture medium, using a gas expander module. **(e)** Detection of numerous gas bubbles in medium without a gas expander module.

important prerequisite for the generation of optimal constructs is the ability to simulate a number of physiological parameters. The artificial interstitial materials could be molded to any desired shape in order to perfectly surround the tissue construct (Fig. 1e and f; and Figs. 2–4). Our basic container design consists of a base plate and a lid made of polycarbonate (Fig. 2a). In a perfusion container the tissue construct is mounted onto the base plate. A lid filled with artificial interstitium is then secured on top. Lid and/or base plate feature a medium inlet and a medium outlet on opposing ends. The container is sealed by clamping the lid onto a silicone gasket on the base plate. The advantage of these new containers is a decreased overall height that entails a reduction in dead volume and optimizes medium exchange.

A gradient culture container can be assembled from two identical lids and a modified base plate. Inside the container the tissue construct is secured in an opening of the base plate, where it separates the luminal compartment from the basal compartment (Fig. 2b). All tissue carriers and filter inserts used today ranging between 13 and 47 mm can be integrated into this construction (Fig. 3). Lids are mounted onto the top and bottom of the base plate with the help of a clamp. Upper and lower com-

partments have a set of medium inlets and outlets each, so that individual culture media can be applied. That way tissues can be experimentally exposed to fluid gradients. Epithelia can be cultured in a physiological environment by applying individual media on the luminal and basal sides (Figs. 2b and 3). Connective tissue, muscle tissue, and neural tissue are generated in customized media under permanent perfusion in combination with a specific artificial interstitium (Fig. 4). In addition, it is possible to expose tissue to different liquid or gaseous media as it typically occurs within the living organism.

### IMPROVED TRANSPORT OF OXYGENATED CULTURE MEDIA

Developing tissue must be supplied with a continuous or pulsing flow of fresh culture medium in order to achieve optimal differentiation and to avoid unstirred layers of fluid.<sup>62,63</sup> This is best accomplished with a peristaltic pump able to deliver adjustable pump rates of a few milliliters per hour. Typically the medium is drawn up from the bottom of a storage bottle through tubing and passes through the bottle cap before reaching the contin-

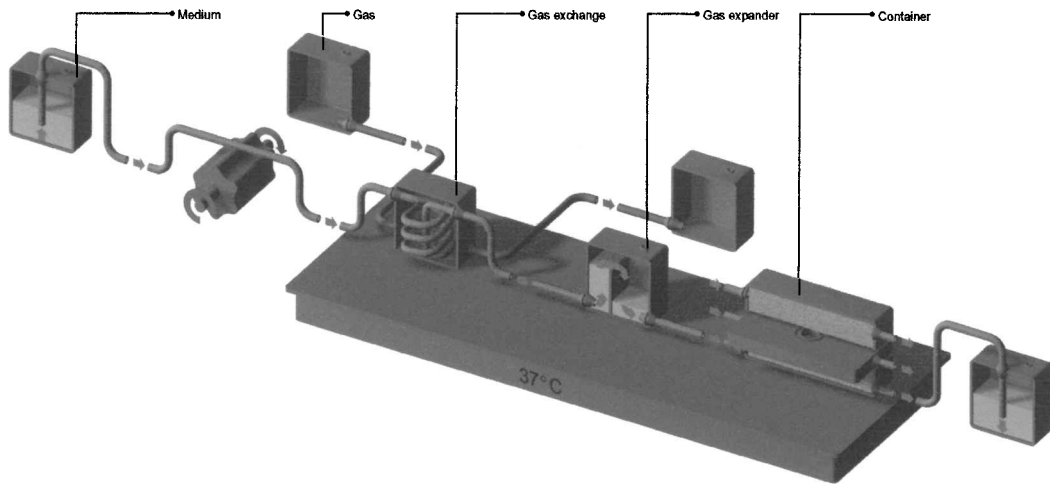

**FIG. 6.** Tissue Factory—a culture line for the generation of artificial tissue consists of a storage bottle for culture medium, a peristaltic pump, a gas exchanger, a gas expander to trap gas bubbles, a culture container, and a bottle to collect waste medium. The temperature of the whole system is maintained by a heating plate. Using a multichannel pump, several culture lines can be run in parallel.

uing tubing. In this scenario the suction pressure of the pump must overcome the difference in elevation within the storage bottle as well as the capillary force resulting from thin tubing. This usually does not cause problems at high pump rates. At low pump rates, however, medium is insufficiently aspirated from the bottle and the amount of air bubbles increases.

Transported medium is saturated with oxygen to guarantee optimal supply for the developing tissue.<sup>64,65</sup> However, the problem in perfusion cultures is that gas bubbles form preferentially at material transitions, where they increase in size and are released at random intervals. This causes microscopic gas bubbles that are transported along with the culture medium. These bubbles increase in size and eventually form an embolus that massively impedes medium flow. Gas bubbles can also accumulate in the culture container, where they lead to a regional shortage of medium supply. Gas bubbles further cause problems in both storage and waste bottles, where growing air accumulations cause erratic breaks in the fluid continuum. In small-diameter tubing this naturally causes massive pressure changes.<sup>66</sup> In a gradient culture setup with luminal and basal compartments where two media must be transported at exactly the same speed and pressure such effects can lead to pressure differences, which in turn can destroy the growing tissue.

To address the problems mentioned above we have developed a medium transport path that consists of only one material and has a small and constant diameter. Consequently, we constructed a new bottle cap that maintains sterility within the storage bottle (Fig. 5a). One opening in the cap is designed for a continuous piece of tubing reaching from the bottom of the storage bottle to the in-

let of the culture container, thus avoiding material transitions along the fluid path. This considerably reduces bubble formation. Another opening holds a sterile filter allowing sterile air to enter the storage bottle as medium is drawn from it. This opening can also be used as an inlet for medium or gases.

## REGULATION OF RESPIRATORY GAS CONTENT

A popular method for medium oxygenation is to blow a pressurized gas mixture into the storage bottle. The disadvantage of this method is the formation of gas bubbles in the medium. These bubbles increase in size, accumulate along the medium transport path, and cause pressure differences within the system. Frequently this method easily leads to infections caused by contaminated gases. Thus, the technical dilemma is to obtain an optimal oxygen saturation while avoiding gas bubble formation with all the associated problems. Our solution is a newly developed gas exchanger module housing a long thin-walled silicone tube for medium to pass through (Fig. 5b). The tubing is wound up into a spiral and is placed into the exchanger module, which features a gas inlet and outlet. The tubing is highly gas permeable and guarantees optimal diffusion of gases between culture medium and the surrounding atmosphere. The gas atmosphere within the exchanger is maintained by a constant flow of the desired gas mixture through the module. In this way the content of oxygen, carbogen, or any other gas can be increased or decreased in the medium by diffusion. In this way it is also possible to adjust the gas partial pres-

tures within the medium under absolutely sterile conditions because the medium does not directly contact the gases. By maintaining a defined carbon dioxide concentration in the medium this method can also be employed to control medium pH via the bicarbonate buffer independently if the system runs in a CO<sub>2</sub> incubator or under atmospheric air. The formation of gas bubbles is minimized in this procedure.

### ELIMINATION OF GAS BUBBLES

For the reasons explained above, gas bubbles must be kept out of the culture container. By using advanced transportation of medium (Fig. 5a) and improved oxygenation techniques (Fig. 5b) as described above the occurrence of bubbles can be greatly reduced, but nevertheless some bubbles will remain in the medium. Consequently, we developed a gas expander module that removes remaining gas bubbles from the culture medium (Fig. 5c).<sup>66</sup> Medium is pumped into a specially designed container, where it rises within a small reservoir. Here the medium can expand and equilibrate before it drops down a barrier. During this process gas bubbles are separated from the medium and collected at the top of the module so that the medium leaving the container is gas saturated but bubble free. The gas expander module itself can be ventilated through a port at

the top. This ventilation port can be coupled with the same port on a second gas expander module. In this way two channels of a gradient setup can be bridged to obtain identical pressures at the luminal and basal lines (Figs. 2b and 3).

Gas bubbles in perfusion lines can be detected by a sensor, which was placed on a 1-mm inner diameter glass capillary at the tube at the inlet port of a culture container. Floating air bubbles were registered by an infrared (IR) gate sensor (Conrad Electronics, Wernberg, Germany). Registered impulses were logged by a personal computer. By combining improved transportation of medium (Fig. 5a) with a gas exchange module (Fig. 5b) and a gas expander module (Fig. 5c), we found that the occurrence of gas bubbles in the culture medium could be drastically reduced (Fig. 5d) compared with medium transport without these tools (Fig. 5e). Most important in this regard is that reduction of gas bubbles by the described method does not affect the content of oxygen in the medium.

### TEMPERATURE CONTROL

Tissue culture must be performed at a constant temperature, usually 37°C. This can be achieved by placing the culture system into an incubator. The disadvantage is the limited accessibility inside the incubator. A better solution is to place all modules of the system under atmo-

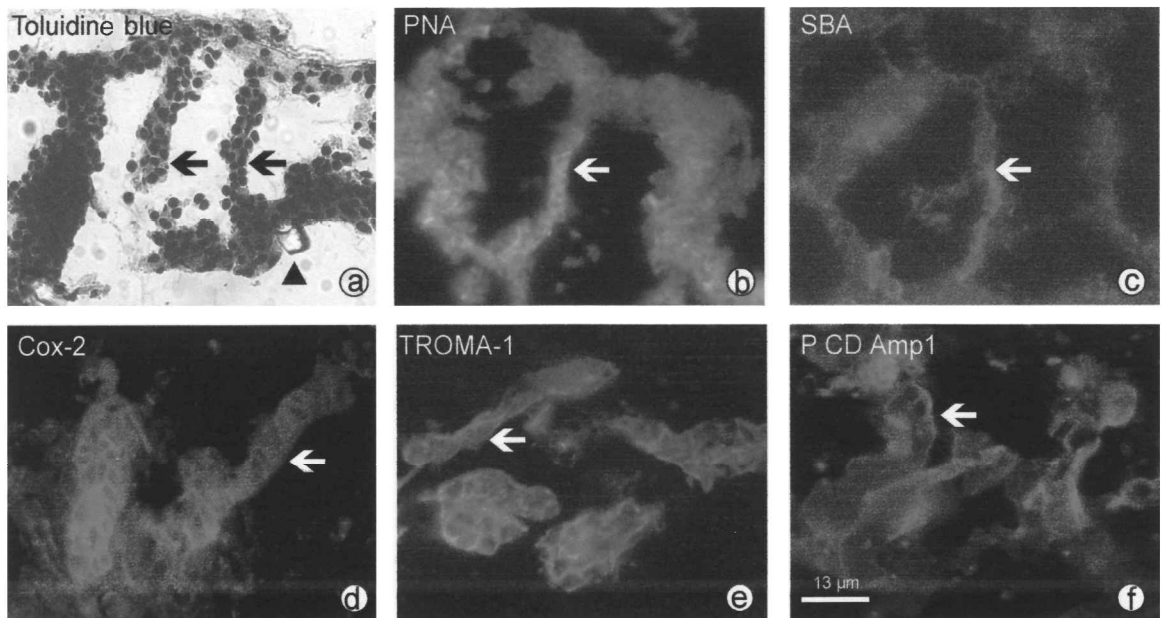

**FIG. 7.** Histochemical analysis of tubular structures derived from renal stem cells after 14 days of perfusion culture in a container with an artificial interstitium. (a) Toluidine blue staining of cryosections shows tubular structures (arrow). (b) PNA and (c) SBA lectins show a fluorescent label on part of the generated tissue. (d) Cox-2 enzyme, (e) TROMA-1, and (f) P CD Amp 1 show positive immunolabel on tubular elements.

spheric air onto a heating plate and cover them with a removable lid. Another solution is to incorporate an electronically controlled heating element into the modules. Such an element could be placed into the module wall or glued onto the module. Low-voltage heating units and circuit breakers should be used in order to avoid electric shock. The heating elements should not be in contact with the culture medium and the cultured tissue. The heating system can be computer monitored continuously concerning power usage and heat output to register potential irregularities in temperature during long-term culture (over weeks).

## MODULAR DESIGN

The complete system consists of several modules that are assembled into a line for tissue culture (Fig. 6). The peristaltic pump maintains a flow of fresh culture medium from the storage bottle through the gas exchanger, gas expander, and culture container. Used medium that leaves the culture container is not recycled but is collected in a waste bottle. Gas exchanger, gas expansion module, and culture container are placed on the surface of a heating unit that maintains a constant ambient temperature. All modules and heating plate are covered with a protective Plexiglas lid. This setup is self-contained to maintain sterility and allows culture of tissue constructs under reproducible conditions for extended periods of time. Several culture lines can be run in parallel, using a multi-channel peristaltic pump.

## FIRST EXPERIENCES

Experiments have been performed to investigate the capacity of renal stem cells to develop into tubular structures. Embryonic tissue was isolated from neonatal rabbits kidney as described earlier.<sup>66</sup> Perfusion culture (1 mL/h) was performed in a container made of polycarbonate with reduced dead space for 14 days (Fig. 2a). The interstitial space inside the culture container was filled with a polyester fleece (Walraf, Grevenbroich, Germany). In applying the new culture technique we could observe in a preliminary experimental series for the first time that the renal stem cell population of the explant developed tubular structures at the interphase between the tissue and the polyester fleece (Fig. 7a). Characterizing the tubular structures with lectins such as peanut agglutinin (PNA; Fig. 7b) and soybean agglutinin (SBA; Fig. 7c) or with antibodies against renal antigens such as COX-2 (Fig. 7d), TROMA-1 (Fig. 7e), or P CD Amp 1 (Fig. 7f) indicated that typical renal features are developed. However, further experiments are in progress to elaborate features of polarization and the state of terminal differentiation.

## PROSPECT

We present a modular system designed for the culture of various tissues under physiological conditions over extended periods of time. The system comprises newly developed culture containers with an artificial interstitium, gas exchanger, and gas expander modules for gas saturation and bubble-free supply to the tissue under improved medium transport.

The culture system is designed for the generation of artificial tissues for the human body and for long-term pharmacological testing. Our goal is to close the experimental gap between conventional cell culture and animal experiments by providing a possibility to culture isolated tissue, organ parts, and artificial tissue constructs over extended periods of time. Tissue constructs can combine different cell types to allow the study of cellular communication after pharmacological application.

Tissue development and maintenance *in vivo* are governed by multifactorial events. The Tissue Factor concept presented in this article combines continuous medium perfusion with an artificial interstitium to recreate these developmental influences *in vitro*.

## ACKNOWLEDGMENT

The development of the concept presented here was supported by Minucells and Minutissue ([www.minucells.de](http://www.minucells.de); Bad Abbach, Germany). The technical assistance of Mrs. Lucia Denk is gratefully acknowledged.

## REFERENCES

1. Vacanti, J.P., and Langer, R. Tissue engineering: the design and fabrication of living replacement devices for surgical reconstruction and transplantation. *Lancet* **354**, SI32, 1999.
2. Langer, R.S., and Vacanti, J.P. Tissue engineering: The challenges ahead. *Sci. Am.* **280**, 86, 1999.
3. Hori, Y., Nakamura, T., Kimura, D., *et al.* Experimental study on tissue engineering of the small intestine by mesenchymal stem cell seeding. *J. Surg. Res.* **102**, 156, 2002.
4. Xu, A.S., and Reid, L.M. Soft, porous poly(D,L-lactide-co-glycolide) microcarriers designed for *ex vivo* studies and for transplantation of adherent cell types including progenitors. *Ann. N.Y. Acad. Sci.* **944**, 144, 2001.
5. Stanworth, S.J., and Newland, A.C. Stem cells: Progress in research and edging towards the clinical setting. *Clin. Med.* **1**, 378, 2001.
6. Bianco, P., and Robey, P.G. Stem cells in tissue engineering. *Nature* **414**, 118, 2001.
7. Vacanti, J.P., Langer, R., Upton, J., *et al.* Transplantation of cells in matrices for tissue regeneration. *Adv. Drug Deliv. Rev.* **33**, 165, 1998.
8. Nerem, R.M., and Seliktar, D. Vascular tissue engineering. *Annu. Rev. Biomed. Eng.* **3**, 225, 2001.



9. Jahoda, C.A., and Reynolds, A.J. Hair follicle dermal sheath cells: Unsung participants in wound healing. *Lancet* **358**, 1445, 2001.
10. Kaps, C., Bramlage, C., Smolian, H., *et al.* Bone morphogenetic proteins promote cartilage differentiation and protect engineered artificial cartilage from fibroblast invasion and destruction. *Arthritis Rheum.* **46**, 149, 2002.
11. Erickson, G.R., Gimble, J.M., Franklin, D.M., *et al.* Chondrogenic potential of adipose tissue-derived stromal cells in vitro and in vivo. *Biochem. Biophys. Res. Commun.* **18**, 763, 2002.
12. Fisher, J.P., Vehof, J.W., Dean, D., *et al.* Soft and hard tissue response to photocrosslinked poly(propylene fumarate) scaffolds in a rabbit model. *J. Biomed. Mater. Res.* **59**, 547, 2002.
13. Obradovic, B., Martin, I., Padera, R.F., *et al.* Integration of engineered cartilage. *J. Orthop. Res.* **19**, 1089, 2001.
14. Luyten, F.P., Dell'Accio, F., and De Bari, C. Skeletal tissue engineering: Opportunities and challenges. *Best Pract. Res. Clin. Rheumatol.* **15**, 759, 2001.
15. Shimizu, T., Yamato, M., Isoi, Y., *et al.* Fabrication of pulsatile cardiac tissue grafts using a novel 3-dimensional cell sheet manipulation technique and temperature-responsive cell culture surfaces. *Circ. Res.* **90**, 40, 2002.
16. Dillon, G.P., Yu, X., Sridharan, A., *et al.* The influence of physical structure and charge on neurite extension in a 3D hydrogel scaffold. *J. Biomater. Sci. Polym. Ed.* **9**, 1049, 1998.
17. Woerly, S. Restorative surgery of the central nervous system by means of tissue engineering using NeuroGel implants. *Neurosurg. Rev.* **23**, 59, 2000.
18. Ziegelaar, B.W., Aigner, J., Staudenmaier, R., *et al.* The characterisation of human respiratory epithelial cells cultured on resorbable scaffolds: First steps towards a tissue engineered tracheal replacement. *Biomaterials* **23**, 1425, 2002.
19. Murphy, C.L., and Sambanis, A. Effect of oxygen tension and alginate encapsulation on restoration of the differentiated phenotype of passaged chondrocytes. *Tissue Eng.* **7**, 791, 2001.
20. Bhadriraju, K., and Hansen, L.K. Hepatocyte adhesion, growth and differentiated function on RGD-containing proteins. *Biomaterials* **21**, 267, 2000.
21. Doll, B., Sfeir, C., Winn, S., *et al.* Critical aspects of tissue-engineered therapy for bone regeneration. *Crit. Rev. Eukaryot. Gene Expr.* **11**, 173, 2001.
22. Ojeh, N.O., Frame, J.D., and Navsaria, H.A. In vitro characterization of an artificial dermal scaffold. *Tissue Eng.* **7**, 457, 2001.
23. Kuberka, M., von Heimburg, D., Schoof, H., *et al.* Magnification of the pore size in biodegradable collagen sponges. *Int. J. Artif. Organs* **25**, 67, 2002.
24. Huttmacher, D.W. Scaffolds in tissue engineering bone and cartilage. *Biomaterials* **21**, 2529, 2000.
25. Ohgushi, H., and Caplan, A.I. Stem cell technology and bioceramics: From cell to gene engineering. *J. Biomed. Mater. Res.* **48**, 913, 1999.
26. Linhart, W., Peters, F., Lehmann, W., *et al.* Biologically and chemically optimized composites of carbonated apatite and polyglycolide as bone substitution materials. *J. Biomed. Mater. Res.* **54**, 162, 2001.
27. Folch, A., and Toner, M. Microengineering of cellular interactions. *Annu. Rev. Biomed. Eng.* **2**, 227, 2000.
28. Francis, K., and Palsson, B.O. Effective intercellular communication distances are determined by the relative time constants for cyto/chemokine secretion and diffusion. *Proc. Natl. Acad. Sci. U.S.A.* **94**, 12258, 1997.
29. Boyan, B.D., Hummert, T.W., Dean, D.D., *et al.* Role of material surfaces in regulating bone and cartilage cell response. *Biomaterials* **17**, 137, 1996.
30. Korke, R., Rink, A., Seow, T.K., *et al.* Genomic and proteomic perspectives in cell culture engineering. *J. Biotechnol.* **94**, 73, 2002.
31. Yamato, M., Konno, C., Utsumi, M., *et al.* Thermally responsive polymer-grafted surfaces facilitate patterned cell seeding and co-culture. *Biomaterials* **23**, 561, 2002.
32. Feng, M., Peng, J., Song, C., *et al.* Mammalian cell cultivation in space. *Microgravity Sci. Technol.* **7**, 207, 1994.
33. Bradamante, Z., Kostovic-Knezevic, L., Levak-Svajger, B., *et al.* Differentiation of the secondary elastic cartilage in the external ear of the rat. *Int. J. Dev. Biol.* **35**, 311, 1991.
34. Merker, H.J., Lilja, S., Barrach, H.J., *et al.* Formation of an atypical collagen and cartilage pattern in limb bud cultures by highly sulfated GAG. *Virchows Arch. A Pathol. Anat. Histol.* **380**, 11, 1978.
35. Schmidt, J., Livne, E., Erfle, V., *et al.* Morphology and in vivo growth characteristics of an atypical murine proliferative osseous lesion induced in vitro. *Cancer Res.* **46**, 3090, 1986.
36. Korossis, S.A., Fisher, J., and Ingham, E. Cardiac valve replacement: A bioengineering approach. *Biomed. Mater. Eng.* **10**, 83, 2000.
37. Steinhoff, G., Stock, U., Karim, N., *et al.* Tissue engineering of pulmonary heart valves on allogenic acellular matrix conduits: In vivo restoration of valve tissue. *Circulation* **102**, III50, 2000.
38. Hoerstrup, S.P., Sodian, R., Daebritz, S., *et al.* Functional living trileaflet heart valves grown in vitro. *Circulation* **102**, III44, 2000.
39. Kim, S.S., and Vacanti, J.P. The current status of tissue engineering as potential therapy. *Semin. Pediatr. Surg.* **8**, 119, 1999.
40. Takezawa, T., Inoue, M., Aoki, S., *et al.* Concept for organ engineering: A reconstruction method of rat liver for in vitro culture. *Tissue Eng.* **6**, 641, 2000.
41. Papas, K.K., Long, R.C., Jr., Sambanis, A., *et al.* Development of a bioartificial pancreas. I. Long-term propagation and basal and induced secretion from entrapped  $\beta$  TC3 cell cultures. *Biotechnol. Bioeng.* **66**, 219, 1999.
42. Tziampazis, E., and Sambanis, A. Tissue engineering of a bioartificial pancreas: Modeling the cell environment and device function. *Biotechnol. Prog.* **11**, 115, 1995.
43. Kaufmann, P.M., Fiegel, H.C., Kneser, U., *et al.* Influence of pancreatic islets on growth and differentiation of hepatocytes in co-culture. *Tissue Eng.* **5**, 583, 1999.
44. Humes, H.D. Bioartificial kidney for full renal replacement therapy. *Semin. Nephrol.* **20**, 71, 2000.
45. Humes, H.D., MacKay, S.M., Funke, A.J., *et al.* Tissue engineering of a bioartificial renal tubule assist device: In vitro transport and metabolic characteristics. *Kidney Int.* **55**, 2502, 1999.

46. Jockenhoevel, S., Zund, G., Hoerstrup, S.P., *et al.* Cardiovascular tissue engineering: A new laminar flow chamber for in vitro improvement of mechanical tissue properties. *ASAIO J.* **48**, 8, 2002.
47. Kremer, M., Lang, E., and Berger, A. Organotypical engineering of differentiated composite-skin equivalents of human keratinocytes in a collagen-GAG matrix (INTEGRA artificial skin) in a perfusion culture system. *Langenbecks Arch. Surg.* **386**, 357, 2001.
48. Minuth, W.W., Schumacher, K., Strehl, R., *et al.* Physiological and cell biological aspects of perfusion culture technique employed to generate differentiated tissues for long term biomaterial testing and tissue engineering. *J. Biomater. Sci. Polym. Ed.* **11**, 495, 2000.
49. Mizuno, S., Allemann, F., and Glowacki, J. Effects of medium perfusion on matrix production by bovine chondrocytes in three-dimensional collagen sponges. *J. Biomed. Mater. Res.* **56**, 368, 2001.
50. Ma, T., Yang, S.T., and Kniss, D.A. Oxygen tension influences proliferation and differentiation in a tissue-engineered model of placental trophoblast-like cells. *Tissue Eng.* **7**, 495, 2001.
51. Tessmar, J.K., Mikos, A.G., and Gopferich, A. Amine-reactive biodegradable diblock copolymers. *Biomacromolecules* **3**, 194, 2002.
52. Elisseff, J., McIntosh, W., Fu, K., *et al.* Controlled-release of IGF-I and TGF- $\beta_1$  in a photopolymerizing hydrogel for cartilage tissue engineering. *J. Orthop. Res.* **19**, 1098, 2001.
53. VandeVord, P.J., Matthew, H.W., DeSilva, S.P., *et al.* Evaluation of the biocompatibility of a chitosan scaffold in mice. *J. Biomed. Mater. Res.* **59**, 585, 2002.
54. Passaretti, D., Silverman, R.P., Huang, W., *et al.* Cultured chondrocytes produce injectable tissue-engineered cartilage in hydrogel polymer. *Tissue Eng.* **7**, 805, 2001.
55. Murray, M.M., and Spector, M. The migration of cells from the ruptured human anterior cruciate ligament into collagen-glycosaminoglycan regeneration templates in vitro. *Biomaterials* **22**, 2393, 2001.
56. van Susante, J.L.C., Pieper, J., Buma, P., *et al.* Linkage of chondroitin-sulfate to type I collagen scaffolds stimulates the bioactivity of seeded chondrocytes in vitro. *Biomaterials* **22**, 2359, 2001.
57. Rowley, J.A., and Mooney, D.J. Alginate type and RGD density control myoblast phenotype. *J. Biomed. Mater. Res.* **60**, 217, 2002.
58. Mann, B.K., Gobin, A.S., Tsai, A.T., *et al.* Smooth muscle cell growth in photopolymerized hydrogels with cell adhesive and proteolytically degradable domains: Synthetic ECM analogs for tissue engineering. *Biomaterials* **22**, 3045, 2001.
59. Bhadriraju, K., and Hansen, L.K. Hepatocyte adhesion, growth and differentiated function on RGD-containing proteins. *Biomaterials* **21**, 267, 2000.
60. Burdick, J.A., Mason, M.N., and Anseth, K.S. In situ forming lactic acid based orthopaedic biomaterials: Influence of oligomer chemistry on osteoblast attachment and function. *J. Biomater. Sci. Polym. Ed.* **12**, 1253, 2001.
61. Mann, B.K., and West, J.L. Cell adhesion peptides alter smooth muscle cell adhesion, proliferation, migration, and matrix protein synthesis on modified surfaces and in polymer scaffolds. *J. Biomed. Mater. Res.* **60**, 110, 2002.
62. Mates van Lobensels, E., Anderson, J.C., Hildebrandt, J., *et al.* Modeling diffusion limitation of gas exchange in lungs containing perfluorocarbon. *J. Appl. Physiol.* **86**, 273, 1999.
63. Collier, K.A., and O'Donnell, M.J. Analysis of epithelial transport by measurement of  $K^+$ ,  $Cl^-$  and pH gradients in extracellular unstirred layers: Ion secretion and reabsorption by Malpighian tubules of *Rhodnius prolixus*. *J. Exp. Biol.* **200**, 1627, 1997.
64. Murphy, C.L., and Sambanis, A. Effect of oxygen tension and alginate encapsulation on restoration of the differentiated phenotype of passaged chondrocytes. *Tissue Eng.* **7**, 791, 2001.
65. Ma, T., Yang, S.T., and Kniss, D.A. Oxygen tension influences proliferation and differentiation in a tissue-engineered model of placental trophoblast-like cells. *Tissue Eng.* **7**, 495, 2001.
66. Schumacher, K., Strehl, R., de Vries, U., *et al.* Advanced technique for long term culture of epithelia in a continuous luminal-basal medium gradient. *Biomaterials* **23**, 805, 2002.

Address reprint requests to:  
 Will W. Minuth, Ph.D.  
 Department of Anatomy  
 University of Regensburg  
 Universitätsstrasse 31  
 D-93053 Regensburg, Germany

E-mail: will.minuth@vkl.uni-regensburg.de